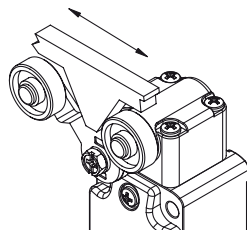
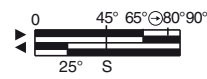
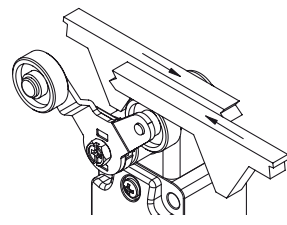
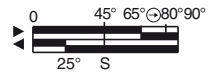

Contact type:

- R** = snap action
- L** = slow action
- LO** = slow action overlapped
- LS** = slow action shifted
- LV** = slow action shifted and spaced
- LI** = slow action independent
- LA** = slow action closer
- A** = electronic PNP

Contact blocks

| | Other rollers available. See on page 28 | With stainless steel roller on request | With stainless steel roller on request | Rope switch for signalling |
|-----------------|---|---|---|----------------------------|
| 5 | R FD 557-M2 \oplus 1NO+1NC | FD 541-M2 \oplus 1NO+1NC | FD 542-M2 \oplus 1NO+1NC | FD 576-M2 1NO+1NC |
| 6 | L FD 657-M2 \oplus 1NO+1NC | Bistable switch with single track lyra lever | Bistable switch with dual track lyra lever | FD 676-M2 1NO+1NC |
| 7 | LO FD 757-M2 \oplus 1NO+1NC | | | FD 776-M2 1NO+1NC |
| 9 | L FD 957-M2 \oplus 2NC |   S = mechanical switching point positive opening on contact 21-22 only |   S = mechanical switching point positive opening on contact 21-22 only | FD 976-M2 2NO |
| 10 | L FD 1057-M2 2NO | | | FD 1076-M2 2NC |
| 11 | R FD 1157-M2 \oplus 2NC | | | FD 1176-M2 2NO |
| 12 | R FD 1257-M2 2NO | | | FD 1276-M2 2NC |
| 13 | LV FD 1357-M2 \oplus 2NC | | | FD 1376-M2 2NO |
| 14 | LS FD 1457-M2 \oplus 2NC | | | FD 1476-M2 2NO |
| 15 | LS FD 1557-M2 2NO | | | FD 1576-M2 2NC |
| 16 | LI FD 1657-M2 \oplus 2NC | | | FD 1876-M2 1NO+1NC |
| 18 | LA FD 1857-M2 \oplus 1NO+1NC | | | FD 2076-M2 2NO+1NC |
| 20 | L FD 2057-M2 \oplus 1NO+2NC | | | FD 2176-M2 3NC |
| 21 | L FD 2157-M2 \oplus 3NC | FD 2276-M2 1NO+2NC | | |
| 22 | L FD 2257-M2 \oplus 2NO+1NC | FD 276-M2 2x(1NO-1NC) | | |
| 2 | R FD 257-M2 2x(1NO-1NC) | | | |
| E1 | A FD E157-M2 1NO-1NC | | | |
| Max. speed | page 237 - type 1 | 0.5 m/s with cam at 30° | 0.5 m/s with cam at 30° | 0.5 m/s |
| Min. force | 0.1 Nm (0.25 Nm \oplus) | 0.21 Nm (0.36 Nm \oplus) | 0.21 Nm (0.36 Nm \oplus) | initial 20 N - final 40 N |
| Travel diagrams | page 238 - group 4 | | | page 238 - group 6 |

All measures in the drawings are in mm

 Items with code on **green** background are stock items

Accessories See page 225